

KERB GRAB – KG21

Installing Kerb Grab

1. Inspect the Kerb Grab for damage. Ensure that the threaded adjustment handle turns freely in both directions.
2. Remove the spring locking pin from the packaged position.
3. Open the extension tube until it is fully open.
4. Slide back the stabilizer to the locked position.
5. Use the spring lock that was removed to secure the sliding stabilizer to the extension tube.
6. Turn the threaded adjustment handle fully to open the clamping portion of the Kerb Grab.
7. Adjust the sliding stabilizer to the required length, which should be the thickness of the concrete wall.
8. Secure the stabilizer with the spring pin to the hole closest to the wall.
9. Turn the threaded adjustment handle clockwise to tighten the jaw until the red inspection gauge disappears.
10. Check installed components after each shift and after each adjustment (at least once per day).
11. If any component has to be removed for any reason, **the operator must be tied off to a secure point. Do NOT tie off to the fences or post. This system is NOT a tie-off point!**

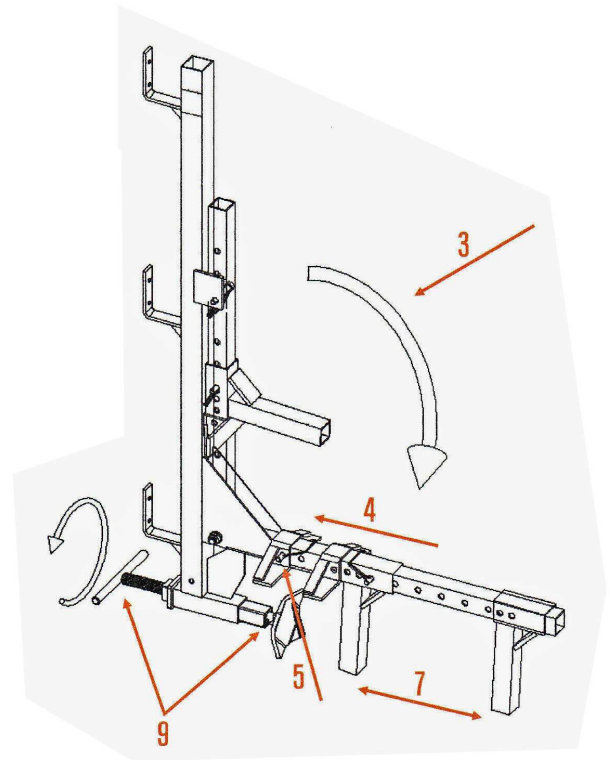

Dismantling Kerb Grab – KG21

1. Remove any Speed Wire or other locking materials from the temporary guardrail or Safety Fence that has been mounted on the Kerb Grab.
2. Remove the temporary guardrail or Safety Fence from the Kerb Grab and place it away from your work area so as not to impede additional removal operations.
3. Loosen the threaded adjustment handle counter clockwise until sufficient slack is available to lift the Kerb Grab from its seated position.
4. Remove the Kerb Grab off of the parapet wall.
5. Collapse the Kerb Grab by reversing the installation instructions listed above.